

GOTIE

USER MANUAL

SLOW JUICER



GSJ-600



GSJ-610



GSJ-620

SPECIFICATION

- power: 200W
- nominal voltage: 230V ~ 50 Hz
- max continuous operating time: 20 minutes
- rotation speed: 45-55 RPM
- BPA free

PRODUCTS FEATURES

- 1. Non-grinding juicing method featured by slow squeezing is adopted for the product**, so the natural flavor and nutrient elements of fruits and vegetables are well retained. The product has multiple functions, including making vegetable juice and fruit juice, etc.
- 2.** The squeezing cup may be separated with the mainframe, and it is convenient to clean.
- 3.** Dual-switch design makes the product safer (make the squeezing cup installed onto the mainframe; apply the front cover of squeezing body, and then turn on the switch to make the juicer run).

Warning: The product is applicable to family use, and it is inapplicable to commercial use, otherwise its service life may be shortened. Don't use the unit if the filter damaged.

SAFETY NOTES

Please carefully read the manual before use the juicer, and please use

the machine according to the instruction book. Be sure not to use the product for other purposes.

- 1.** Please do not make the machine share the same power supply with other high-power electric appliances, and the product shall be used with 30A leakage circuit breaker installed.
- 2.** To prevent electric leakage and other hazards, please use the machine according to the instruction book.
- 3.** It is forbidden to make the machine power line and plug immersed into water or other liquids.
- 4.** Be careful to watch it during operation of the machine.
- 5.** If the parts or product structure is found to be damaged (particularly, the safetyprotection device and power line are damaged), please do not use the machine. Do not attempt to repair it by yourself, and it shall be

repaired by professionals.

6. Do not let children or the disabled operate the machine under the condition that they have not received any guidance or supervision.

7. Please do not make the product used on or beside high-temperature gas or electric stove.

8. It is forbidden to use finger, spoon or chopstick to push fruits/vegetables into the feed inlet of the machine.

9. Please do not touch or move any moving part during operation of the machine.

10. Please do not make metal sheet or other conducting material inserted into the juicer, so as to prevent fire or short circuit.

11. Before the machine is cleaned, moved or it is not used, please pull out the plug.

12. Be sure not to put the machine near inflammable goods.

13. If the supply cord is damaged, it must be replaced by the manufacturer, its service agent or similarly qualified persons in order to avoid accident.

14. Be sure to hold the plug with hands when the plug is pulled out, and it is forbidden to pull the power line or touch the wire with wet hands.

15. Please be sure that the juicer is put on a firm plane before it is used.

16. Please be sure to pull out the power plug after the use.

17. Switch off the appliance and disconnect from supply before changing accessories or approaching parts that move in use.

18. Always disconnect the appliance from the supply if it is left unattended and before assembling, disassembling or cleaning.

19. This appliance shall not be used by children. Keep the appliance and its cord out of reach of children.

20. Appliances can be used by persons with reduced physical, sensory or mental capabilities or lack of experience and knowledge if they have been given supervision or instruction concerning use of the appliance in a safe way and if they understand the hazards involved.

21. Children shall not play with the appliance.

22. This appliance can be used by children and persons with reduced physical, sensory or mental capabilities or lack of experience and knowledge if they have been given supervision or instruction concerning use of the appliance in a safe way and understand the hazards involved. Children shall not play with the appliance. Cleaning and user maintenance shall not be made by children without supervision.

ELEMENTS

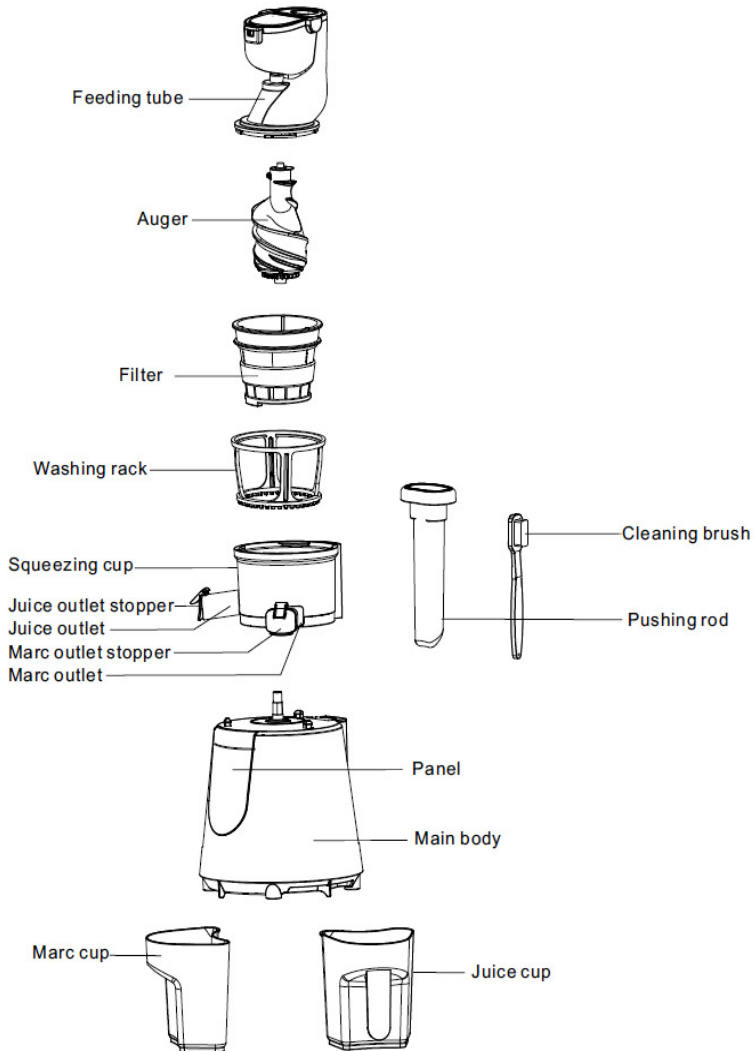

Pictures are for reference only

RUBBER PAD INSTALLATION

1. Before the juice cup is installed, please confirm whether the rubber pad of the marc outlet at the bottom of the juice cup is properly installed. Make the rubber pad of marc outlet inserted into the rectangular slot. Make the rubber pad of marc outlet properly inserted.

Notes: The rubber pad must be properly installed, otherwise leakage phenomenon may occur.

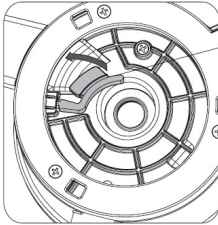

Rubber pad

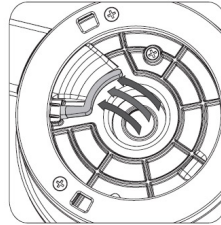

2. Installation juice outlet stopper

The stopper is separately packed during the packaging process. use, make the bayonet juice outlet align with the fixed column on juice outlet and inserted. Before use make the bayonet juice outlet stopper align with the fixed column on juice outlet and inserted.

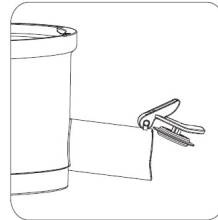
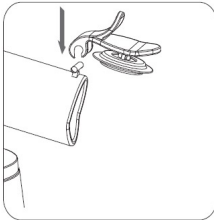

3. Installation of marc outlet stopper

The stopper is separately packed during the packaging process. Before use, make the aligning column on the fixing piece marc outlet stopper align with the fixing groove on the outlet and inserted.

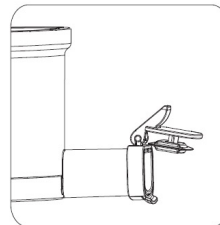
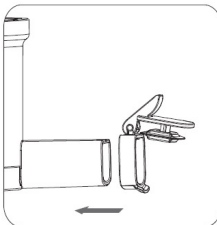

ASSEMBLY OF COMPLETE MACHINE

Step 6

Make the juice cup and marc cup respectively installed to the juice outlet of juice cup and the position that is under the marc outlet.

Step 5

Make the feeding tube installed to the squeezing cup.
See the figure, make the mark “^” on the cover of squeezing cup and the mark “^” on the squeezing cup aligned and perform installation downwards, and then rotate it at clockwise direction.

Step 4

Make the filter installed into the squeezing cup. See the figure. Make the mark “^” on the juicing filter and the mark “^” on the squeezing cup aligned and perform installation downwards.

Step 3

Make the auger installed into the filter.
Make the hexagonal axis in the auger align with the outer-hexagonal axis of motor and perform installation downwards, and then rotate it at clockwise direction.

Step 2

Make the filter installed into the washing rack.

Step 1

Make the squeezing cup installed onto the main body. See the figure. Make the trim strip on the squeezing cup align with the trim strip on the main body and perform installation downwards, and then rotate it at clockwise direction.

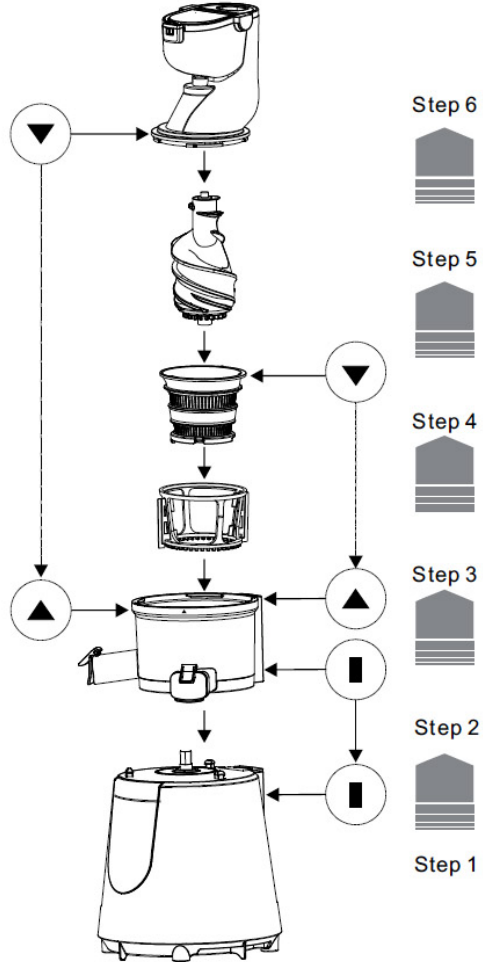

FUNCTION DESCRIPTION



Hard



Medium



Soft



Mixed Juice



Vegetable



Jam



Salad



Nuts milk





Washing

No.	Program	Food recommendation
1	Hard	<ol style="list-style-type: none"> 1. Suit hard vegetable and fruit, Carrot, Beet etc; 2. Cut fruit into 1.5-2cm block or Length; 3. Put fruit to juicer slowly and ensure marc can go out smoothly ; 4. Touch button " R" if unit is blocked during working;
2	Medium	<ol style="list-style-type: none"> 1. Suit for not too hard fruit, such as Apple, Pear etc ;
3	Soft	<ol style="list-style-type: none"> 1. Suit for soft fruit, such as Watermelon, grapes etc; 2. Put fruit to juicer slowly and ensure marc can go out smoothly ; 3. For soft fruit, they can not be squeezeed fully and marc will remain little juice;
4	Mixed Juice	<ol style="list-style-type: none"> 1. It is better for soft fruit mix some hard fruit on this program; 2. During working, Juicer will stop seconds for the second fruit;
5	Vegetable	<ol style="list-style-type: none"> 1. The program suit for vegatable juice; 2. Please use some hard and less fiber vegetable for juice; 3. For celery and other much fiber vegetable, please cut it about 2cm length; 4. Put vegetable to juicer slowly and ensure marc can go out smoothly;
6	Jam	<ol style="list-style-type: none"> 1. This program suit for soft fruit such as: tomato, Strawberry; 2. Stem the Juice outlet by stopper; 3. Put fruit to juicer and squeez it about 3 mins, ensure juice less than squeezing cup max scale mark; 4. Add some yogurt or honey according to taste, Clean juicer; 5. Jam function is only available in models GSJ-600 and GSJ-610;
7	Nuts milk	<ol style="list-style-type: none"> 1. Nuts such as Soybean/ Peanut /almond must be soaked 8-12 hours; 2. Put soaked nuts and water to squeeze together; 3. Fully cook the juice and add milk or sugar according to taste;
8	Salad	<ol style="list-style-type: none"> 1. This function is option, suit for carrot, cucumber, onion etc; 2. Need one set special accessories for Salad function; 3. The salad function can cut vegetable to strip or piece by 2 different knives; 4. Make salad according to need; 5. Salad function is only useful in models GSJ-610 and GSJ-620 with included accesory. For model GSJ-600 salad accesorry is available separately;
9	Washing	<ol style="list-style-type: none"> 1. Before using this Slow Juicer, close the juice and Marc outlet stopper; 2. Pour some clean water to squeezing cup and touch "washing" button; 3. Open juice and marc outlet stopper and pour out water, continue making juice;

1.  key: It is power and stop key. After the power is plugged in and the cover of juice cup is applied, the buzzer will beep and the power lamp will flash to enter into standby status; click the [power] key for power on

and the power lamp will be normally on. At this time, the default menu is 『hard』 vegetable and fruit. when all lights are on and press the 『power』 key, the machine will power off after 5 seconds' reversal operation.

2.  key: Click the 『menu』 key for switchover in circulation (from left to right, from up to down).

3.  key: Click the 『start』 key, and the selected menu operation will start. The machine will pause if the 『start』 key is clicked at squeezing status; and the machine will continue the work after the 『start』 key is clicked again.

4.  key: Click the 『R』 key, the machine works in backward rotary, and the machine will pause after 10 seconds' reversal operation. (The 『R』 key may be used at both pause or squeezing status).

Notes: If switch over to other menu options under squeezing status, please click the 『power』key firstly, and then click the 『menu』 key. If all the display lamps flash and the buzzer beeps, the machine will pause and enter into protection status. The machine will recover to the default status by clicking any key. The machine will stop automatically after running for 20min at squeezing status, Cool machine about 20 minutes and restart it again if need.

USE METHOD

1. Use method of cover:

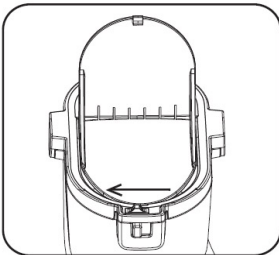

Push the button leftwards, and the swiveling cover will bounce automatically.

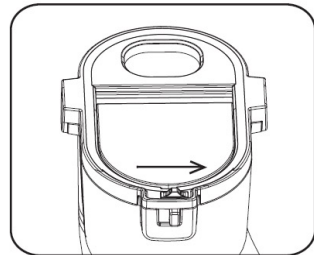

Press the swiveling cover downwards, and then push the button rightwards to lock it.

2. Juicing method:

(1) Use method of big- caliber feed port:

1. Push the cover-opening button leftwards and the swiveling cover will bounce automatically, and the feed port will appear.
2. At this time, the whole apple may be put into the feed port, rotate and press the swiveling cover until the apple enters into the squeezing chamber.
3. The pushing rod may be used for assistance during the squeezing process.

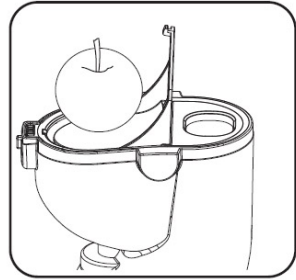

Big feed port: The whole apple, pear, tomato

Notes:

- 1. The fruits and vegetables with the diameter of over 75 mm or irregular shapes shall be put into the machine after being cut into small size, so as to prevent unsmooth feeding.**
- 2. Much fiber vegetable should be cut to 2cm length.**

(2) Use method of small feed port:

1. Make the swiveling cover rotated to be horizontal, and then push the cover-opening button rightwards to lock the swiveling cover.
2. Make clean fruits and vegetables (big-sized fruits and vegetables shall be cut into proper size) put into the feed port, and push them inwards by using the pushing rod.

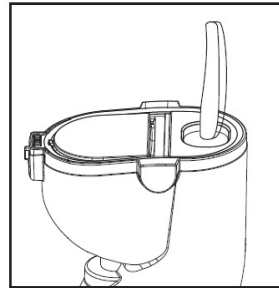

Small feed port: carrots, celery etc.

NOTES FOR USE

* Please read the following contents before use.

- 1 .The materials shall be put into the machine slowly one by one, and new materials shall be put into it after the previous materials have been squeezed.**
- 2. The materials with large fiber content (such as celery) shall be put into the machine after being cut into the blocks with appropriate size (10-20mm). (The materials with particularly strong fiber shall be put into themachine slowly after being cut into the blocks of about 20mm).**

3. When the carrot that have been stored at low temperature for over 1 week is used for squeezing, it is better to make it squeezed together with the materials with large water content (such as pear or orange), because that such carrot has small water content.

The juice amount will be larger if new materials are put into the machine after the previous materials have been squeezed (the juice amount will vary with the water content of materials).

4. The juice amount will be small if the materials are not fresh. When dry materials stored in refrigerator are used for squeezing, the materials shall be squeezed after being immersed in clear water for sufficient water absorption, so that the effect will be better.

5. Hard materials are not applicable to make juice (such as kudzu, sugarcane, etc).

6. There will be certain friction noise when carrot (hard flesh) or apple (hard peel) is used for squeezing, but this has no impact on the product.

7. Juice will be splash from the feed inlet when such materials as cherries, tomatoes and grapes are used for squeezing.

DISASSEMBLY METHOD

1. Stop the machine and pull out the plug.

2. Grip the feeding tube by hands, and rotate the feeding tube - see figure (1) clockwise direction to the position indicated on figure (2) and then take out the feeding tube upwards.

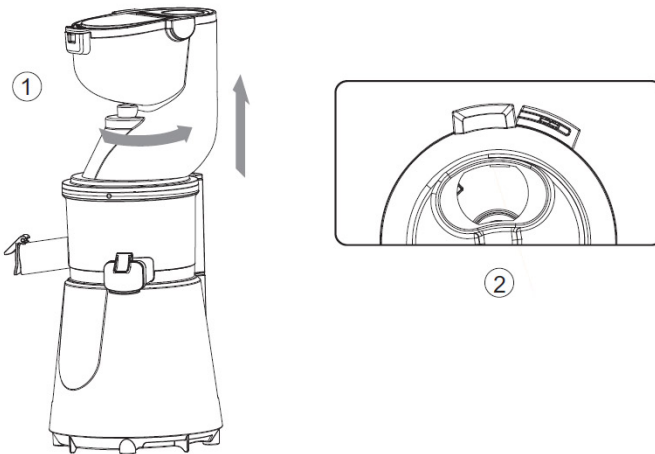

3. Grip the juice outlet on the squeezing cup, and left it upwards for separation - see figure (3)
4. Take out the filter from the squeezing cup + auger+ washing rack - see figure (4)
5. Respectively disassemble auger, filter and washing rack - see figure (5)

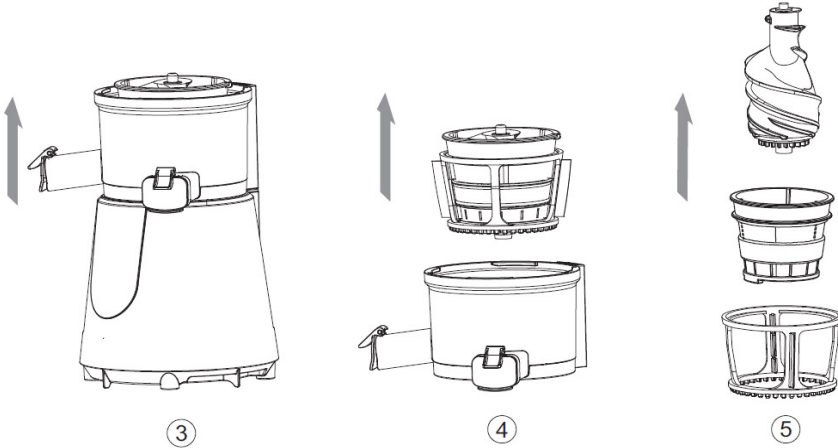

CLEANING

1. Cleaning before use

1. After the complete machine is assembled, make the juice outlet stopper and the marc outlet stopper respectively installed to the juice outlet and marc outlet of the juice cup, and it shall be at closed status.
2. Connect the power. Add 500 ml water into the juice cup from the feed port; start the cleaning function in menu option, and the machine will perform cleaning automatically.
3. The machine will stop automatically after the cleaning is completed.

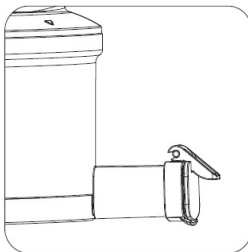

Marc outlet stopper is at closed status

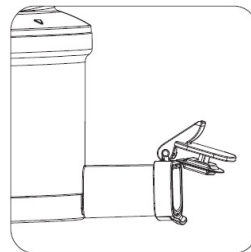

Marc outlet stopper is at open status

2. Cleaning after use

Clean the disassembled parts with clear water, and please clean them with brush if meshes are blocked up by marc.

Note : Please do not use iron wire brush, abradant or sharp cleaning tool for the cleaning.

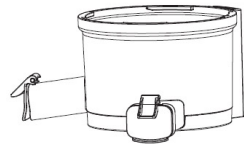
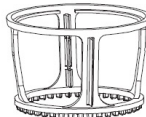
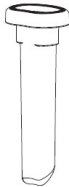
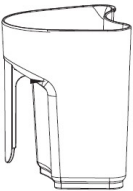
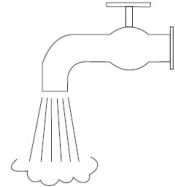
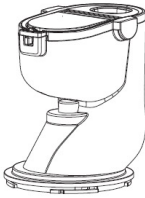

3. After cleaning

Please dry the cleaned parts and store them in a clean and ventilating place.

Notes:

1. Please wash the machine in time after use, otherwise the dreg will attach to the container, which will affect the assembly and cleaning, and even result in perform-ance reduction.

2. The rubber pad at the bottom of the squeezing cup may be washed. Please refer to the contents in page 4.

SALAD MAKER ACCESSORIES INSTALLATION

1. Install Salad maker parts

First, Install Rod to unit the Motor axis;

Second, Install all other parts according to follows picture

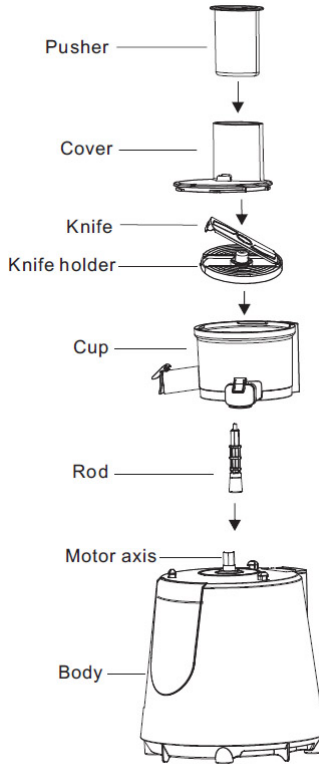

2. Install salad maker knife to knife holder

Insert The knife one side to the Holder and

push down Knife another side as follows picture

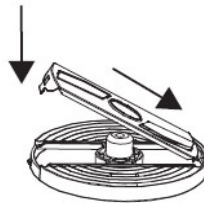

TROUBLESHOOTING

Phenomenon	Cause	Troubleshooting method
The running machine stops suddenly	<ol style="list-style-type: none"> 1. Whether the power plug is inserted properly. 2. The quantity of materials put into the machine is too much 3. Hard fruits and vegetables are not cut. 4. Continuous working time more than 20 Mins. 	<ol style="list-style-type: none"> 1. Make the plug inserted into the socket. 2. First, press "R" for 2-3s to make the materials return upwards; then choose function button and start again(repeat the process for about 3 times). If the machine still does not run please clean the machine and then use it. 3. Hard fruits and vegetables (such as carrot) shall be squeezed after being cut into strips. 4. Cool the machine about 20 Mins and restart it if need.
The juice amount is small	Materials stored in refrigerator too long before squeezing.	<ol style="list-style-type: none"> 1. The juice amount will be increased if the materials are squeezed after being immersed in clear water for sufficient water absorption. 2. Use fresh fruit.
Juice flows out of the mainframe	The rubber pad at the bottom of squeezing cup is not installed properly.	Please reinstall the squeezing rubber pad by referring to the installation method.
There is abnormal noise	<ol style="list-style-type: none"> 1. Accessories are not properly installed. 2. The machine is put on oblique ground. 3. Parts cause extrusion sound during squeezing. 	<ol style="list-style-type: none"> 1. Inspect whether the accessories are properly installed after the machine stops. 2. Please put the machine on a plane. 3. The sound caused by extrusion of fruits and vegetables, and please do not worry about it.
The container and accessories are dyed after use	<ol style="list-style-type: none"> 1. Dreg attaches to the container 2. The container and accessories are liable to be dyed when materials with pigment (such as carrot, spinach, etc.) are used for squeezing. 	<ol style="list-style-type: none"> 1. Clean the machine in time after use 2. Clean the machine with detergent after use.

JUICE RECIPES

Carrot-Celery Juice

Mix two parts carrot juice to one part celery juice. Add a few drops of lemon juice for added flavor.

Carrot-Celery-Apple Juice

Mix equal amounts of carrot, celery and apple juice.

Carrot-Cabbage Juice

Mix three parts carrot juice to one part cabbage juice.

Carrot-Cucumber-Beet Juice

Combine five ounces carrot juice, two ounces cucumber juice, and one-ounce beet juice. Or, one cucumber peeled, one red beet and the remainder carrot.

Carrot-Celery-Parsley Juice

Combine four ounces carrot juice, three ounces of celery juice and one ounce of parsley juice. IMPORTANT: One ounce of any leafy green vegetable can be substituted for the parsley juice.

Carrot-Parsley Juice

Combine seven ounces of carrot juice to one ounce of parsley juice.

Apple-Carrot-Beet Juice

Add juice from one beet to equal parts of apple and carrot juice.

Carrot-Cucumber Juice

Combine four parts carrot juice to one part cucumber juice.

Apple-Beet Juice

Combine five parts apple juice to one part beet juice.

Apple Grape Juice

Combine equal parts apple juice and grape juice. Juice grapes first, then apples.

Apple Lemonade

Very small wedge of lemon with peel and about four apples (mixed variety).

Pear Lemonade

Small wedge of lemon with peel. Any type of pear.

Orange-Grapefruit-Lemon Juice

Combine four ounces orange juice, four ounces grapefruit juice and one ounce lemon juice.

Apple-Orange Juice

Combine equal parts of apple juice and orange juice.

Cantaloupe and Honeydew

Combine equal parts. Peel these, as the outside is difficult to clean.

Carrot-Apple-Spinach Juice

Combine eight ounces carrot juice, six ounces apple juice and two ounces of spinach juice.

Carrot-Lettuce-Celery Juice

Combine equal parts of carrot, lettuce and celery juice.

Carrot-Beet-Spinach Juice

Combine ten ounces carrot juice, three ounces of spinach juice and three ounces of beet juice.

GOTIE.EU